

Materiali: il nostro vero fiore all'occhiello

Vetro e legno sono i protagonisti di un design in continua evoluzione per soddisfare le esigenze del vivere quotidiano. Un'accurata selezione di materie prime, trasformate in elementi di stile con tecniche di lavorazione all'avanguardia, consente la realizzazione di porte e pareti scorrevoli personalizzabili in ogni dettaglio.

MATERIALS: OUR FEATHER IN THE CAP

Glass and wood are the protagonists of a design that is constantly evolving to meet the needs of contemporary living. A careful selection of premium materials transformed into stylish elements with state-of-the-art processing techniques enables the creation of doors and sliding partitions that can be tailored in every detail.



 **SOLO SU MISURA**
TAILOR-MADE ONLY

Height 259,8
Base 95,3

2
A3
BASEMENT ELECT PLAN
SCALE 1:100

Tre collezioni, infinite possibilità

Tre stili differenti, pensati per adattarsi ad ogni situazione con la massima flessibilità. Le nostre collezioni sono state concepite in modo da essere declinabili in tutte le tipologie di apertura e perfettamente integrabili all'interno del vostro ambiente, rispettando sempre l'identità del contesto stilistico.

THREE COLLECTIONS, ENDLESS POSSIBILITIES Three distinct styles conceived to adapt to any situation with the utmost flexibility. Our collections are designed to be applied to all types of openings and to be flawlessly integrated within your environment, pairing perfectly with every style.



Factory

Stile industriale,
design minimale

Industrial style,
minimal design



TuttoVetro

Vetro allo
stato puro

Glass at its
purest



Flat

Classico, moderno,
contemporaneo

Classic, modern,
contemporary

Factory

Porte e sistemi divisori in vetro stratificato di sicurezza con un sottile perimetro di legno massello. Reinterpretazione dello stile industriale, massima espressione del design minimale.

Doors and partitions made of laminated glass with a thin, solid wood border. Reinterpretation of the industrial style, ultimate expression of minimal design.

Modelli | Models

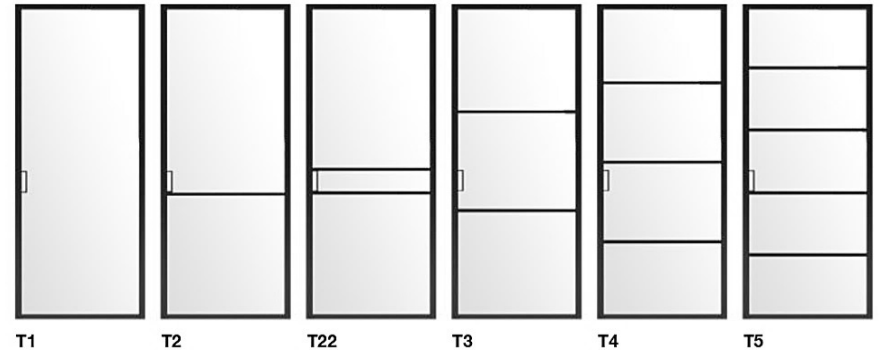

T1

T2

T22

T3

T4

T5

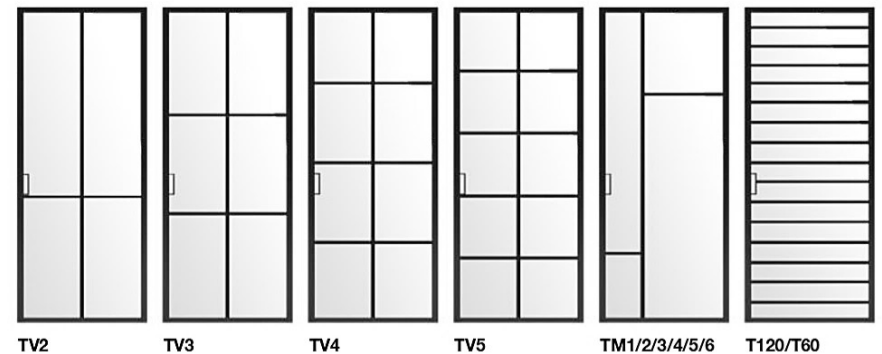

TV2

TV3

TV4

TV5

TM1/2/3/4/5/6

T120/T60

FACTORY | Mod. T1

Anta fissa in vetro
VELLUTO ALBA CH
finitura TOTAL BROWN

Fixed partition, VELLUTO
ALBA CH laminated glass
TOTAL BROWN finish



Nuovi vetri Velluto

Vetri satinati coprenti, disponibili in un'ampia gamma di colori. Ideati per creare un'alternanza di colore, luce ed ombra, con una piacevole sensazione di morbidezza al tatto.

NEW VELLUTO GLASS

Opaque, frosted glass, available in a wide range of colors. Designed to create an alternation of color, light, and shadows, with a pleasant and velvety soft-touch feel.



FACTORY | Mod. T60

Scorrevole per controsoffitto,
vetro stratificato TRASPARENTE
EXTRACHIARO, finitura TOTAL BROWN

Sliding system for false ceiling,
TRASPARENTE EXTRACHIARO
laminated glass, TOTAL BROWN finish

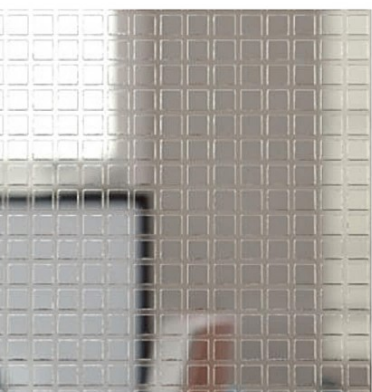

FACTORY | Mod. T3
 Scorrevole con pareti fisse, vetro stratificato
 TRASPARENTE EXTRACHIARO, decoro MILLIMETRATO
 in "VETRO LIQUIDO", finitura TOTAL WHITE

Sliding system with fixed panels, TRASPARENTE
 EXTRACHIARO laminated glass, "VETRO LIQUIDO"
 MILLIMETRATO decoration, TOTAL WHITE finish

FACTORY | Mod. T5 >
 Porte a scomparsa, vetro stratificato TRASPARENTE
 EXTRACHIARO, finitura TOTAL WHITE

Pocket sliding doors, TRASPARENTE EXTRACHIARO
 laminated glass, TOTAL WHITE finish



Soluzioni e partizioni a progetto ideate insieme a voi

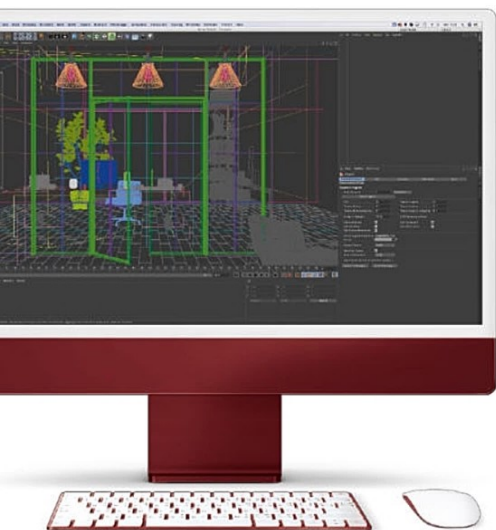
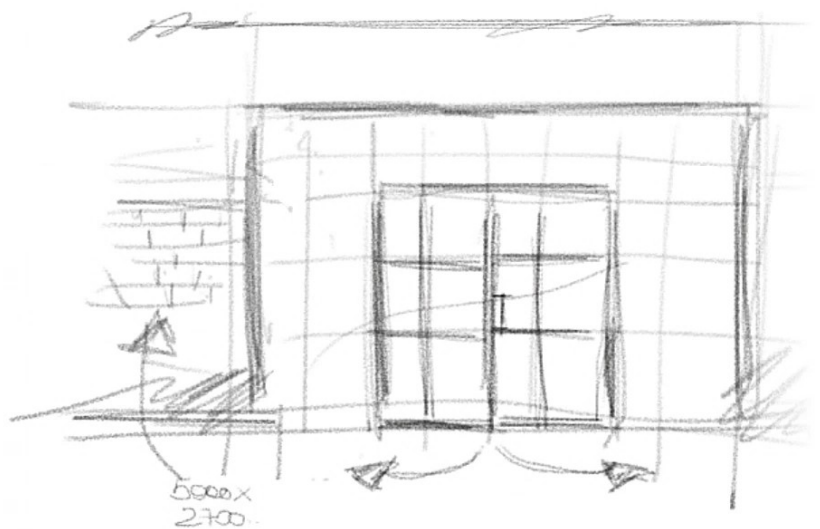

Realizziamo strutture a progetto configurabili e personalizzabili in ogni minimo dettaglio, disegnate per aumentare la vivibilità ed il comfort degli spazi in cui andranno a collocarsi e incontrare lo stile di chi le vivrà nel quotidiano. La libertà creativa si esprime per dar forma a soluzioni divisorie "cucite su misura" che rispondono ai più alti canoni di tecnica ed estetica.

CUSTOM SOLUTIONS AND PARTITIONS DESIGNED TOGETHER WITH YOU

We manufacture made-to-order structures that can be configured and customized in every way, enabling us to increase the livability and comfort of your spaces and meet the stylistic tastes of those who will use them everyday. The creative freedom we offer paves the way for tailor-made partition solutions that meet the highest standards of technique and aesthetics.



FACTORY

Struttura su progetto

Divisorio ad angolo con ante fisse su muretto e anta scorrevole, vetro stratificato TRASPARENTE EXTRACHIARO, finitura TOTAL BLACK

Tailor-made partition

Corner partition with fixed panels on low wall and sliding door, TRASPARENTE EXTRACHIARO laminated glass, TOTAL BLACK finish





FACTORY

Struttura su progetto

Scorrevole con fisso su muretto,
vetro stratificato TRASPARENTE
EXTRACHIARO, finitura TOTAL BROWN

Tailor-made partition

Sliding door with fixed side panels on
low wall, TRASPARENTE EXTRACHIARO
laminated glass, TOTAL BROWN finish

Decorazioni esclusive in "Vetro Liquido"

Tratti tridimensionali sulla superficie del vetro offrono una nuova esperienza visiva e tattile. Una tecnica decorativa proprietaria ed innovativa che dona matericità al vetro, capace di mettere in risalto la luce o generare un effetto schermante. I decori in "Vetro Liquido" sono disponibili in versione trasparente o nera coprente.

EXCLUSIVE "VETRO LIQUIDO" DECORATIONS Three-dimensional designs on the surface of the glass offer a new visual and tactile experience. An exclusive and innovative decorative technique capable of enhancing the glass itself, it can both accentuate and dim the light that shines through it. "Vetro Liquido" designs are available in either clear transparent or opaque black colors.



LA-RETE

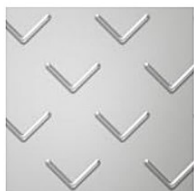

LA-VI



LA-ELLE



LA-CURVA



LA-CI



IL-NIDO



IL-TRATTO



CANNETÉ

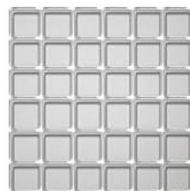

MILLIMETRATO



LE-ONDE



CADRE



SHANGHAI



GRAPHICS

Finiture innovative con un'anima calda in legno massello

Le finiture della collezione Factory sono divise in serie, ognuna con un impatto visivo caratterizzante. I profili utilizzati sono in legno massello di tiglio, per garantire massime prestazioni e stabilità nel tempo.

INNOVATIVE FINISHES WITH A WARM SOLID WOOD CORE The finishes in the Factory collection are divided into series, each with distinctive visual effect. The trims used are solid linden wood to ensure maximum performance and stability over time.



TOTAL BLACK

TOTAL WHITE 9010

TOTAL WHITE



TOTAL BROWN

TITANIO

ALLUMINIO



BRONZO

RAME

EFFETTO CORTEN





FACTORY | Mod. T4
Porta a libro doppia, vetro
stratificato TRASPARENTE
EXTRACHIARO, finitura
TOTAL WHITE

Double folding door,
TRASPARENTE
EXTRACHIARO laminated
glass, TOTAL WHITE finish

FACTORY | Mod. T4

Porta a libro doppia, vetro stratificato
TRASPARENTE EXTRACHIARO,
finitura TOTAL BLACK

Double folding door,
TRASPARENTE EXTRACHIARO
laminated glass, TOTAL BLACK finish





FACTORY | Mod. TM
Scorrevole con pareti fisse,
vetro stratificato TRASPARENTE
EXTRACHIARO, finitura TOTAL BLACK

Sliding system with fixed panels,
TRASPARENTE EXTRACHIARO
laminated glass, TOTAL BLACK finish



FACTORY | Mod. T5

Porta a scomparsa e scorrevole con binario Mini, vetro stratificato
TRASPARENTE EXTRACHIARO, finitura TOTAL BLACK

Pocket and sliding doors with Mini rail, TRASPARENTE EXTRACHIARO
laminated glass, TOTAL BLACK finish



FACTORY | Mod. T3

Porte a battente, vetro stratificato TRASPARENTE EXTRACHIARO,
deco CANNETÉ in "VETRO LIQUIDO", finitura TOTAL BROWN

Swing doors, TRASPARENTE EXTRACHIARO laminated glass, "VETRO
LIQUIDO" CANNETÉ decoration, TOTAL BROWN finish

FACTORY | Mod. T1
Porte a battente con
telaio a filo muro,
vetro stratificato
TRASPARENTE, decoro
IL-TRATTO in "VETRO
LIQUIDO", finitura
TOTAL BLACK

Flush-frame swing
doors, TRASPARENTE
laminated glass. IL-
TRATTO "VETRO
LIQUIDO" decoration,
TOTAL BLACK finish



Oltre le porte

La versatilità della collezione Factory trova massima espressione nella varietà delle possibili applicazioni, superando il concetto di semplice apertura. Lo spazio viene plasmato per creare vere e proprie stanze, spazi di lavoro, cabine armadio o, semplicemente, elementi decorativi capaci di generare diverse atmosfere in un unico ambiente.

BEYOND DOORS

The versatility of the Factory collection is found in the variety of possible applications, going beyond the simple concept of opening. Space is then shaped to create actual rooms, workspaces, walk-in closets or simply decorative elements capable of generating different atmospheres into a single room.

FACTORY | Mod. T22

Porte a scomparsa, vetro stratificato
TRASPARENTE EXTRACHIARO, decoro LE-ONDE
in "VETRO LIQUIDO", finitura TOTAL BLACK

Pocket sliding doors, TRASPARENTE
EXTRACHIARO laminated glass, LE-ONDE "VETRO
LIQUIDO" decoration, TOTAL BLACK finish



FACTORY | Mod. TV5

Divisorio fisso, vetro stratificato
TRASPARENTE EXTRACHIARO,
finitura TOTAL BLACK

Fixed partition, TRASPARENTE
EXTRACHIARO laminated glass,
TOTAL BLACK finish



FACTORY | Mod. TV3

Porta a battente doppia con chiusura "easy
lock", vetro stratificato TRASPARENTE
EXTRACHIARO, finitura TOTAL WHITE

Double swing door with "easy lock" system,
TRASPARENTE EXTRACHIARO laminated
glass, TOTAL WHITE finish





Decoro La-Vi in “Vetro Liquido”
Inconfondibili dettagli di stile

La-Vi “Vetro Liquido” decoration
Unmistakable details of style

FACTORY | Mod. T1

Porta a bilico con anta fissa, vetro stratificato
TRASPARENTE EXTRACHIARO, decoro LA-Vi in
“VETRO LIQUIDO”, finitura TOTAL BLACK

Pivot door with fixed side panel, TRASPARENTE
EXTRACHIARO laminated glass, LA-Vi “VETRO
LIQUIDO” decoration, TOTAL BLACK finish





^ FACTORY | Mod. T3
 Scorrevole per controsoffitto,
 vetro stratificato TRASPARENTE
 EXTRACHIARO, decoro CANNETÉ in
 "VETRO LIQUIDO", finitura BRONZO

Sliding system for false ceiling,
 TRASPARENTE EXTRACHIARO
 laminated glass, "CANNETÉ "VETRO
 LIQUIDO" decoration, BRONZO finish

> FACTORY | Mod. T4
 Scorrevole per controsoffitto,
 vetro stratificato TRASPARENTE
 EXTRACHIARO, finitura TOTAL BLACK

Sliding doors for false ceiling,
 TRASPARENTE EXTRACHIARO
 laminated glass, TOTAL BLACK finish



^ FACTORY | Mod. TV4
 Scorrevole per controsoffitto,
 vetro stratificato TRASPARENTE
 EXTRACHIARO, finitura TOTAL BLACK

Sliding system for false ceiling,
 TRASPARENTE EXTRACHIARO
 laminated glass, TOTAL BLACK finish

v FACTORY | Mod. TV2
 Scorrevole per controsoffitto, vetro stratificato
 TRASPARENTE EXTRACHIARO, decoro CANNETÉ
 in "VETRO LIQUIDO", finitura RAME

Sliding doors for false ceilings, TRASPARENTE
 EXTRACHIARO laminated glass, CANNETÉ
 "VETRO LIQUIDO" decoration, RAME finish



Qual è What is
la forma the shape
del tuo of your
progetto project?



D A T I
T E C N
I C I T
E C H N
I C A L
D A T A

Dati tecnici Technical data

Pag 92 | Factory

- 94 | Porte scorrevoli | Sliding doors
- 96 | Porte a scomparsa | Pocket sliding doors
- 98 | Porte a battente | Swing doors
- 100 | Porte a libro | Folding doors
- 102 | Porte a bilico | Pivot doors

Pag 108 | TuttoVetro

- 110 | Porte scorrevoli | Sliding doors
- 114 | Porte a scomparsa | Pocket sliding doors
- 116 | Porte a battente | Swing doors
- 117 | Porte a ventola e bilico | Double-acting and pivot doors

Pag 126 | Flat

- 128 | Porte scorrevoli | Sliding doors
- 130 | Porte a scomparsa | Pocket sliding doors
- 132 | Porte a battente | Swing doors
- 134 | Porte a libro | Folding doors

Factory

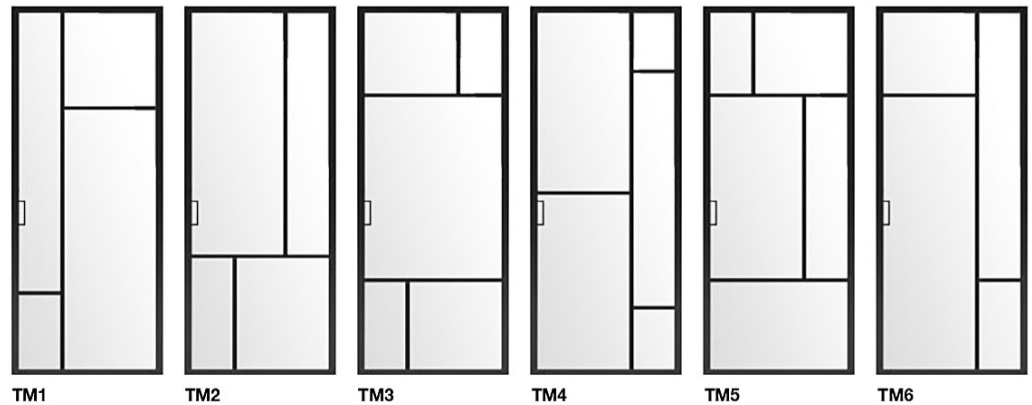
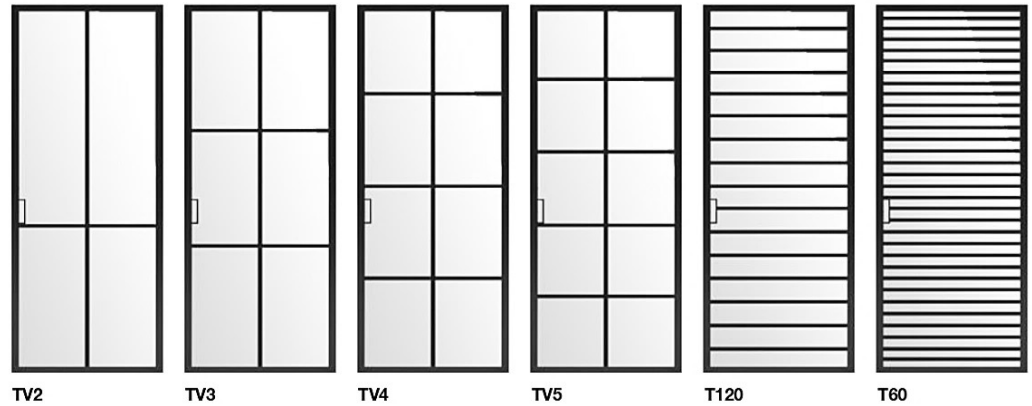
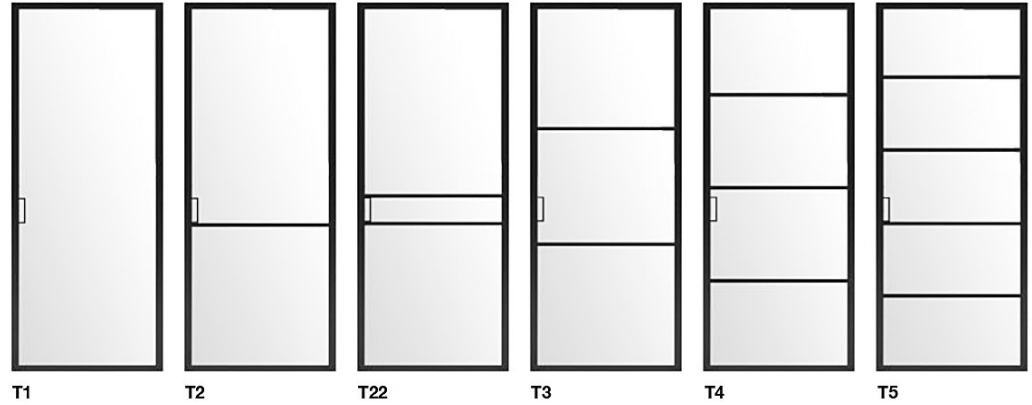

Scorrevole | Sliding

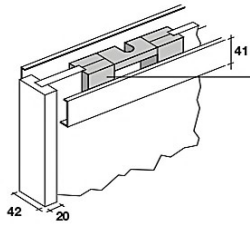

Carter di copertura pinze in alluminio
stessa finitura anta
Aluminium carter to cover clamps
same finish as the panel

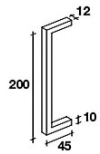

C/20 maniglia (coppia)
stessa finitura anta
C/20 handle (pair) same
finish as the panel

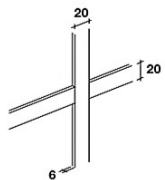

Profili decorativi in legno
Wooden decorative profiles

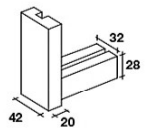

Profili in legno
Wooden profiles

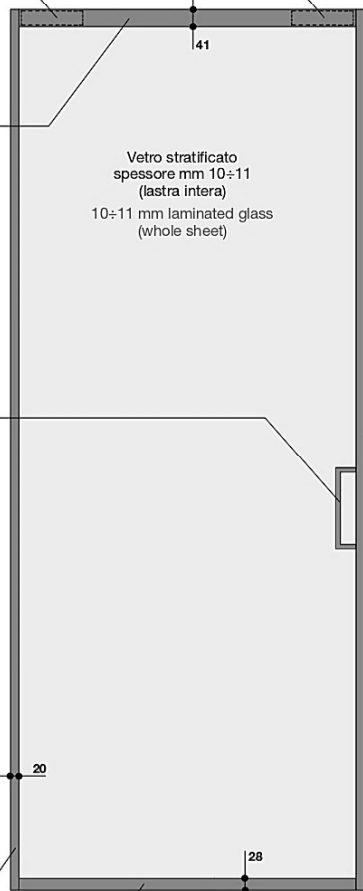

SCORREVOLI ESTERNO VANO A 1 VIA | EXTERNAL 1 WAY SLIDING DOORS

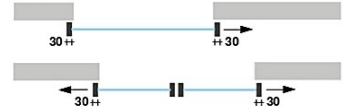
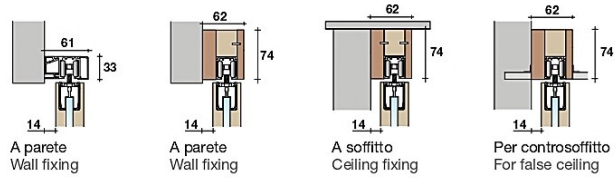

SCORREVOLI ESTERNO VANO A 2 VIE | EXTERNAL 2 WAYS SLIDING DOORS

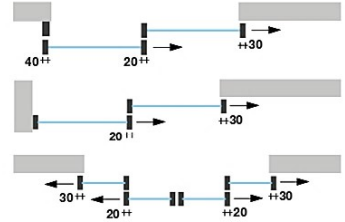
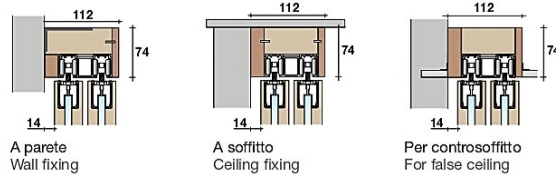

SCORREVOLI ESTERNO VANO A 3 VIE | EXTERNAL 3 WAYS SLIDING DOORS

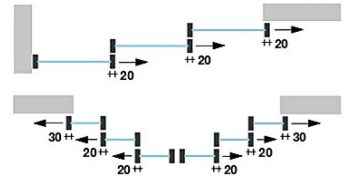
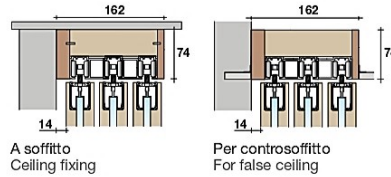

SCORREVOLI INTERNO VANO A 2 VIE | INTERNAL 2 WAYS SLIDING DOORS

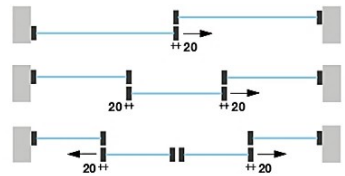
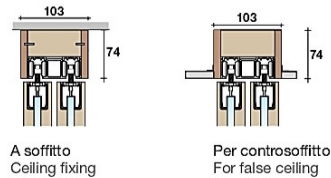

SCORREVOLI INTERNO VANO A 3 VIE | INTERNAL 3 WAYS SLIDING DOORS

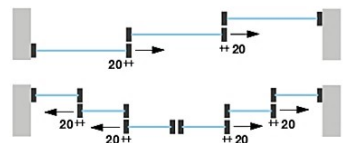
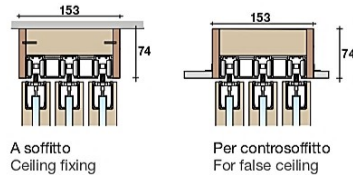

SCORREVOLI INTERNO VANO A 4 VIE | INTERNAL 4 WAYS SLIDING DOORS

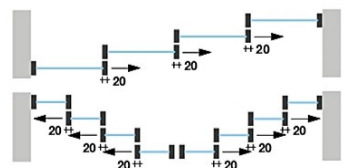
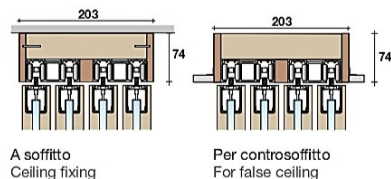

Scomparsa | Pocket sliding

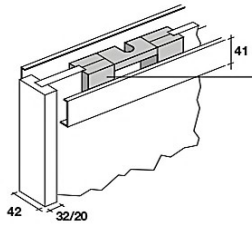

Carter di copertura pinze in alluminio
stessa finitura anta
Aluminium carter to cover clamps
same finish as the panel

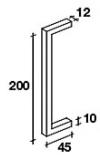

C/20
Maniglia (coppia)
stessa finitura anta
Handle (pair) same
finish as the panel

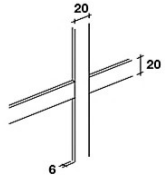

Profili decorativi in legno
Wooden decorative profiles

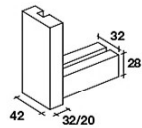

Profili in legno
Wooden profiles

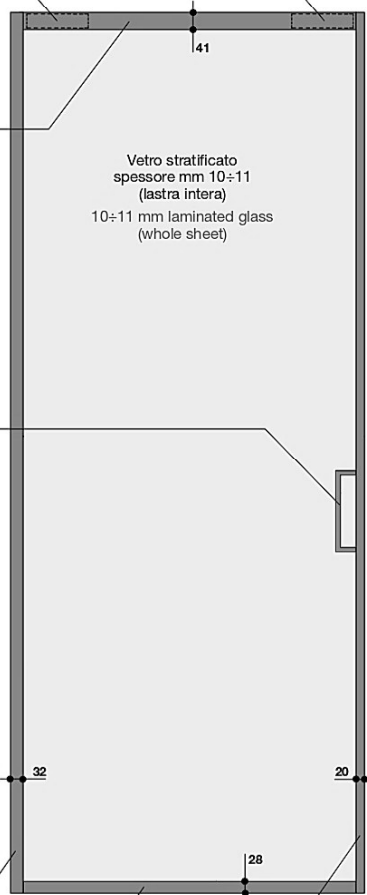

PER CASSONETTI A MURO FINITO | FOR FINISHED WALL METAL BOXES

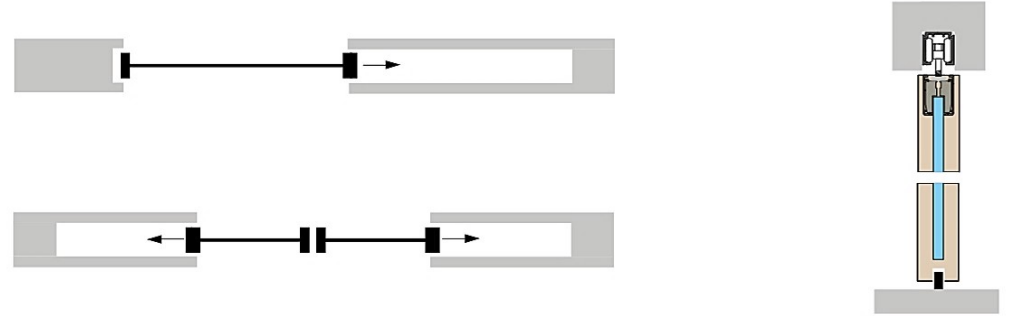

PER CASSONETTI CON KIT STIPITE | FOR METAL BOXES WITH JAMB

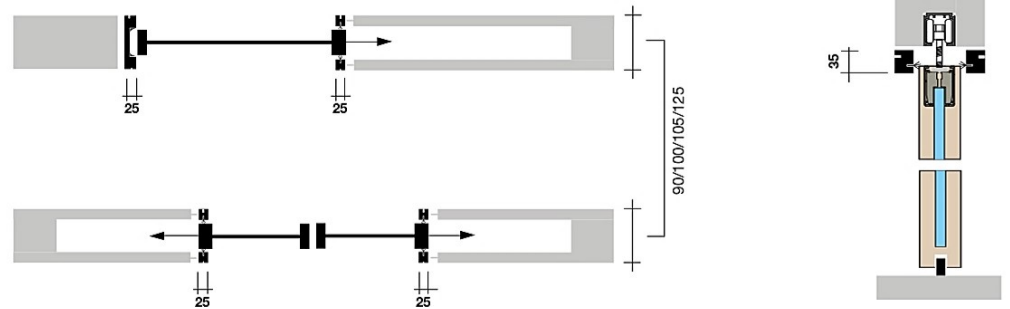

Versione con coprifili telescopici solo dietro (escursione max mm 10)
Version with telescopic trims at the back side only (max travel range 10 mm)

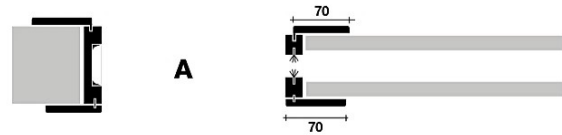

Versione con coprifili telescopici davanti e dietro (escursione max mm 10)
Version with telescopic trims at both front and back sides (max travel range 10 mm)

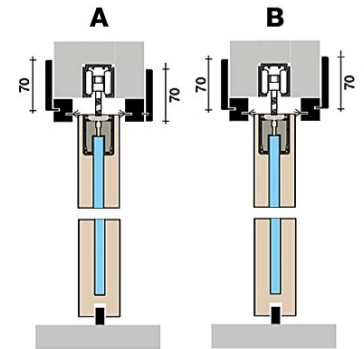
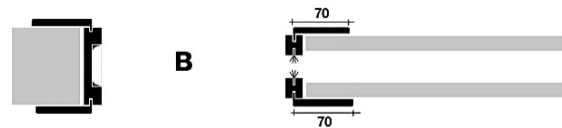

Battente | Swing

PORTA CON SERRATURA E MANIGLIA DOOR WITH LOCK AND HANDLE

Spessore vetro mm 10÷11
Luce netta max mm 900x2400H
10÷11 mm thick glass
clear light opening max 900x2400H mm

MP 2013 F  44
138

N ● B ○ CRS ●

NOTTOLINO WC

NT 2900  20

N ● B ○ CRS ●

SERRATURE - STESSA FINITURA ANTA LOCKS - SAME FINISHINGS AS THE PANEL

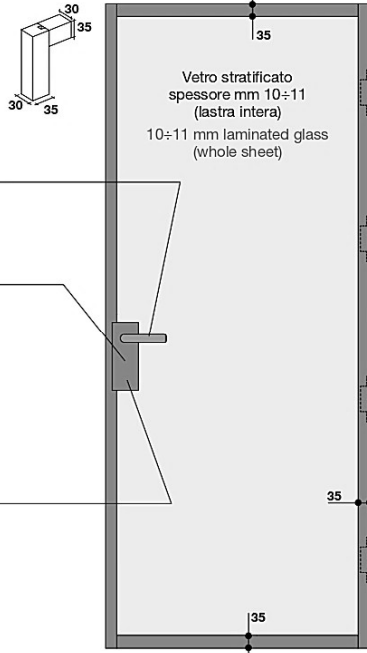
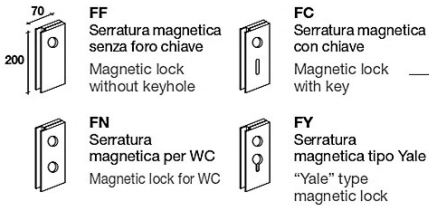

PORTA CON CHIUSURA "EASY-LOCK" (AD ATTRAZIONE MAGNETICA) DOOR WITH "EASY-LOCK" SYSTEM (MAGNETIC ATTRACTION LOCK)

Spessore vetro a seconda delle misure
SPESSORE VETRO mm 10÷11:
Luce netta max mm 900x2400H
SPESSORE VETRO mm 6÷7:
Luce netta max mm 900x2700H
Solo con: Vetri base - Vetri colorati
Vetri tessuto - Specchio chiaro bifacciale - Satinati coprenti

Glass thickness according to the specific size

10÷11 mm THICK GLASS:
Clear light opening max 900x2400H mm

6÷7 mm THICK GLASS AVAILABLE ONLY WITH:
Clear light opening max 900x2700H mm
Base glass - Colored glass - Fabric glass
Clear two-sided mirror - Etched opaque glass

F/20  30
200
Maniglia fissa
Stessa finitura anta
Fixed handle
Same finish as the panel

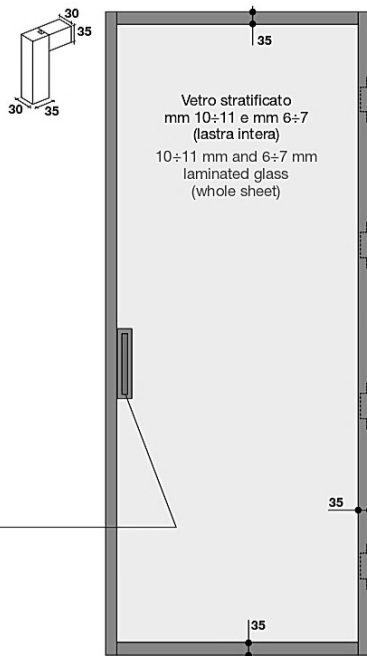

STIPIE IN ALLUMINIO A FILO MURO | FLUSH ALUMINIUM JAMB

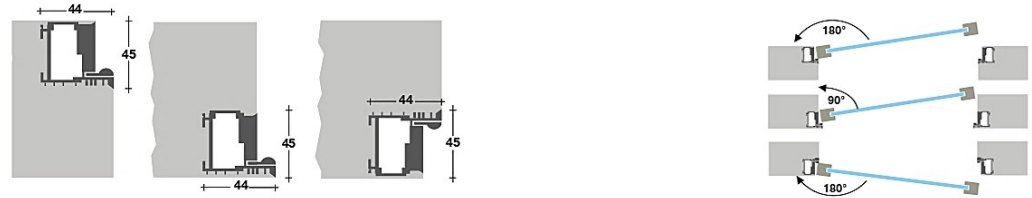

STIPIE PER MURO INTONACATO | JAMB FOR PLASTERED WALLS

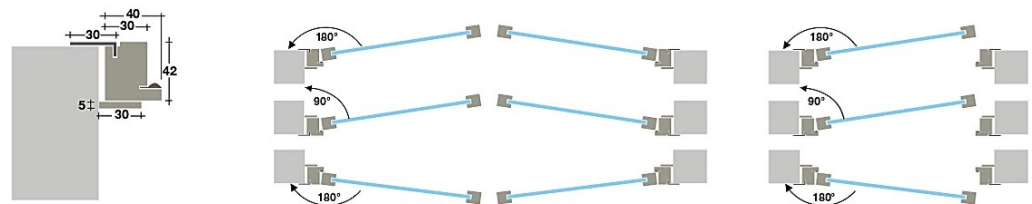

STIPIE PER MURO INTONACATO POSIZIONE CENTRALE | CENTERED JAMB FOR PLASTERED WALLS

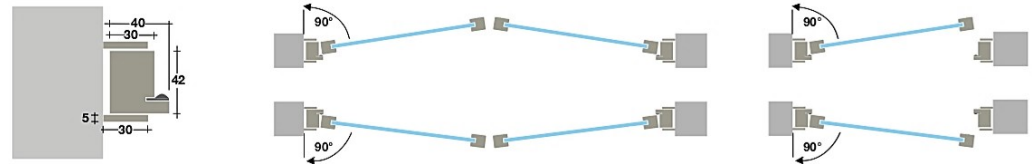

STIPIE PER MURO CON RIVESTIMENTO | JAMB FOR WALLS WITH CLADDING

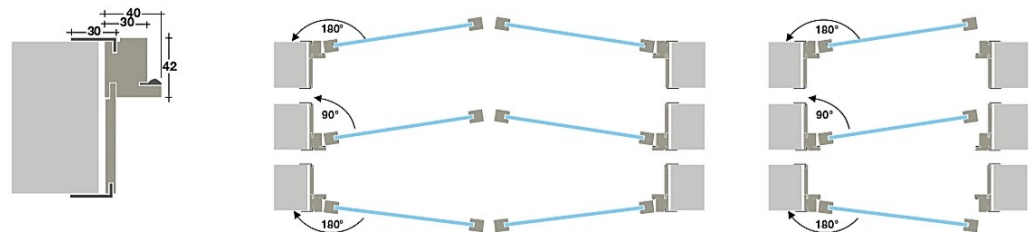

STIPIE PER FALSO TELAIO | JAMB FOR FALSE FRAMES

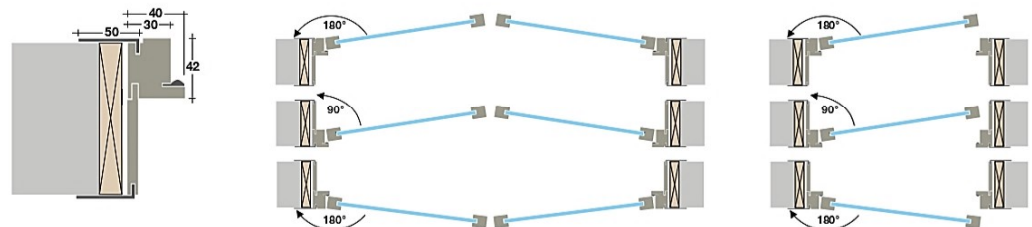

Libro | Folding

PORTA A LIBRO FOLDING DOOR

Spessore vetro mm 6÷7
Solo con: Vetri colorati - Vetri tessuto
Specchio chiaro bifacciale - Satinati coprenti
Luce netta max mm 1200x2700H
6÷7 mm thick glass
Available only with: Base glass
Colored glass - Fabric glass
Clear two-sided mirror - Etched opaque glass
Clear light opening max 1200x2700H mm

PDR
Pendolino
entrambi i lati
Double-sided
retractable knob

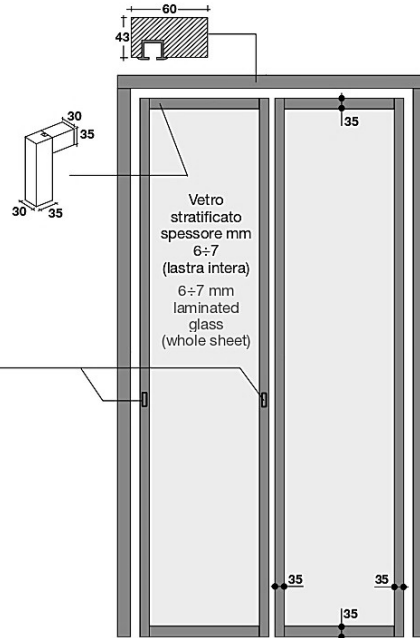
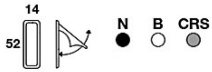

Stipite e profili ante in legno
Wooden jamb and profiles

PORTA A LIBRO DOPPIA DOUBLE FOLDING DOOR

Spessore vetro mm 6÷7
Solo con: Vetri base
Vetri colorati - Vetri tessuto
Specchio chiaro bifacciale - Satinati coprenti
Luce netta max mm 2400x2400H
6÷7 mm thick glass
Available only with: Base glass
Colored glass - Fabric glass
Clear two-sided mirror - Etched opaque glass
Clear light opening max 2400x2400H mm

PDR
Pendolino
entrambi i lati
Double-sided
retractable knob

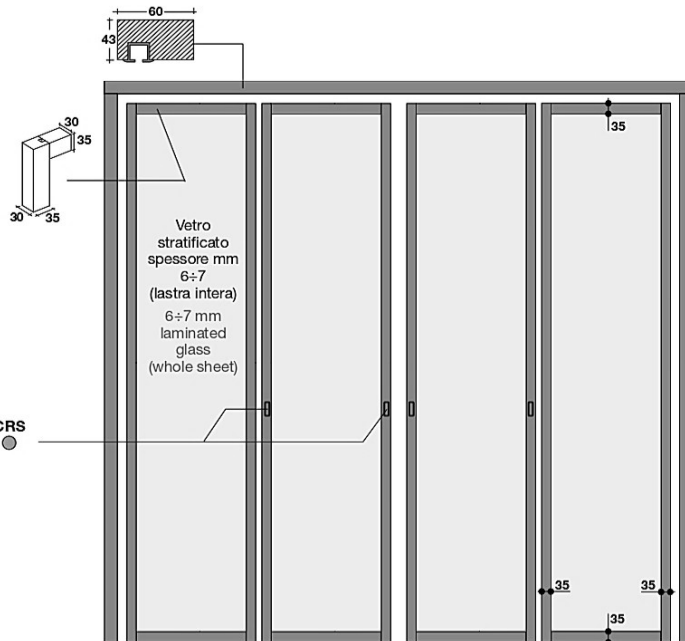
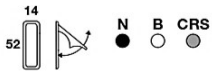

Stipite e profili ante in legno
Wooden jamb and profiles

N: Nero opaco | Matt black **B:** Bianco opaco | Matt white **CRS:** Cromo satinato | Satin chrome

STIPIE PER MURO INTONACATO | JAMB FOR PLASTERED WALLS

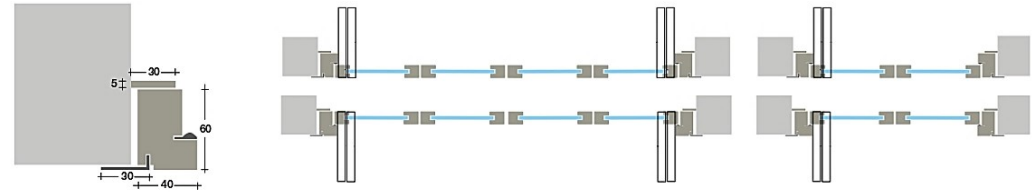

STIPIE PER MURO INTONACATO - POSIZIONE CENTRALE | CENTERED JAMB FOR PLASTERED WALLS

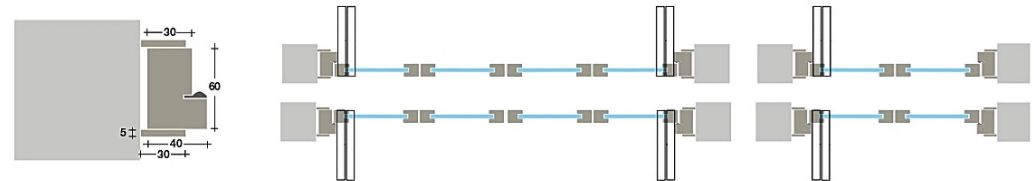

STIPIE PER MURO INTONACATO CON RIVESTIMENTO | JAMB FOR PLASTERED WALL WITH CLADDING

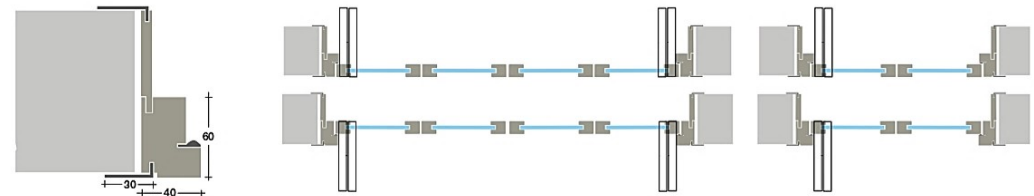

STIPIE PER FALSO TELAIO | JAMB FOR FALSE FRAMES

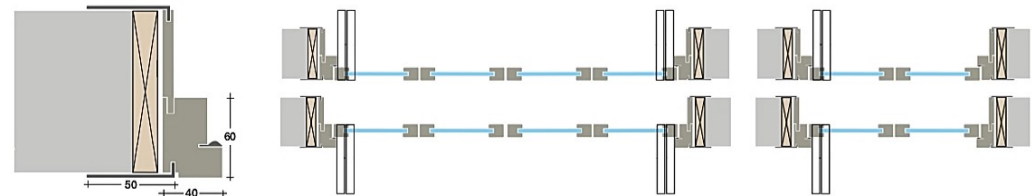

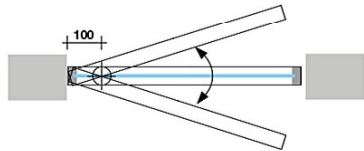
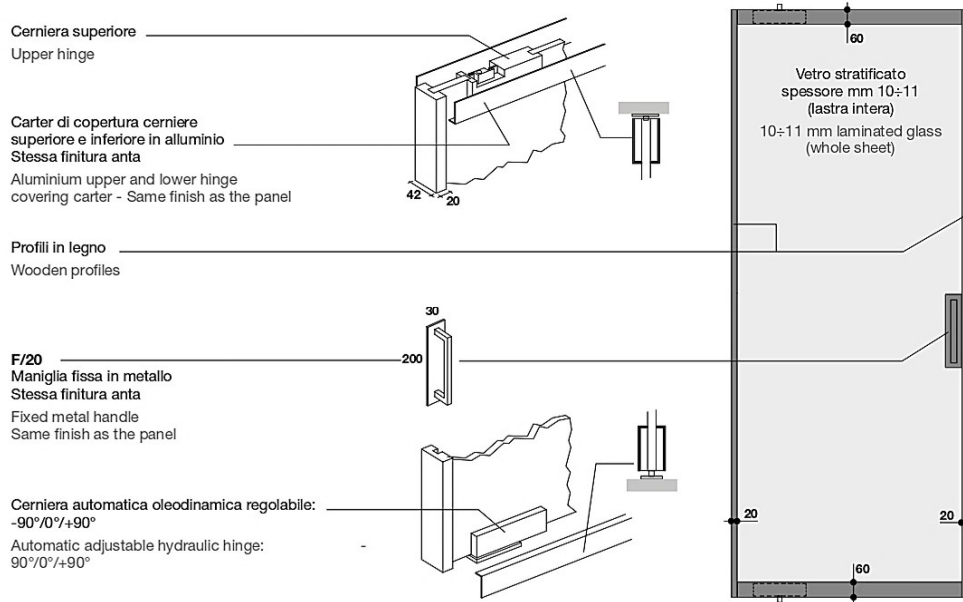

ANTA SINGOLA SINGLE PANEL

Vano max mm 1100x2700H
Compartment 1100x2700H mm max

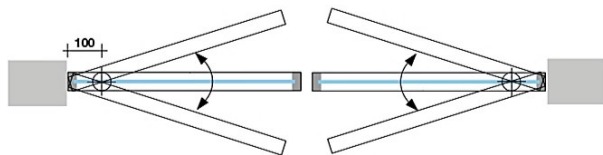

ANTA DOPPIA DOUBLE PANEL

Vano max mm 2200x2700H
Compartment 2200x2700H mm max

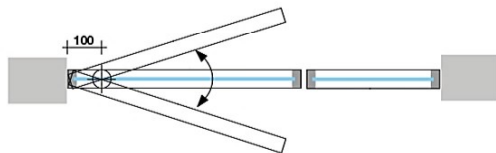

ANTA SINGOLA CON FISSA SINGLE PANEL WITH FIXED ELEMENT

Vano max mm 1800x2700H
Anta apribile max 1100L
Anta fissa max mm 700L
Compartment 1800x2700H mm max
Opening panel 1100L max
Fixed panel 700L max

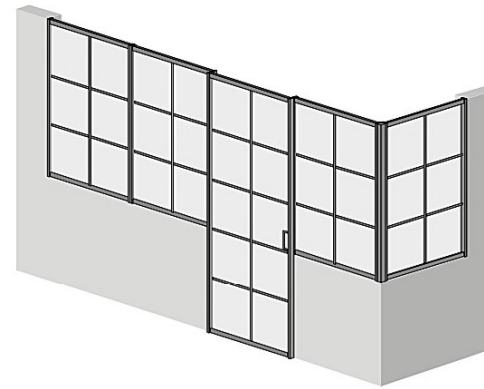

Divisorio ad angolo con ante fisse su muretto e anta scorrevole.
Corner partition with fixed panels on low wall and sliding door.

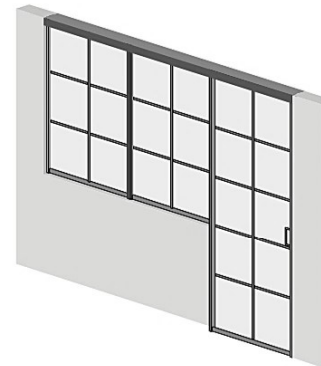

Divisorio con ante fisse su muretto e anta scorrevole.
Partition with fixed panels on low wall and sliding door.

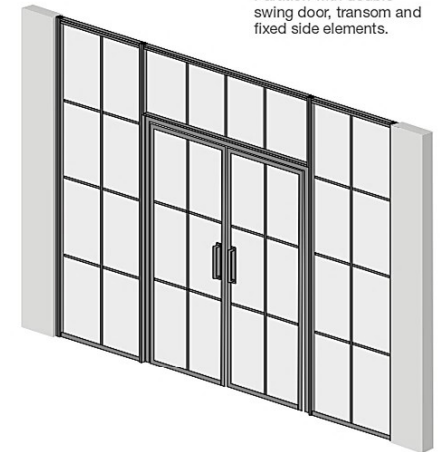

Divisorio con porta a battente doppia, sopra luce e fissi laterali.
Partition with double swing door, transom and fixed side elements.

Divisorio ad angolo con ante fisse e ante scorrevoli.
Corner partition with fixed panels and sliding doors.

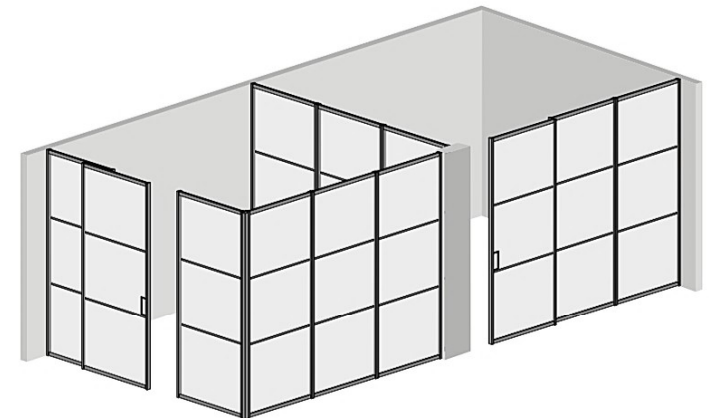

Vetri stratificati | Laminated glass

VETRI BASE | BASE GLASS

Vetri TRASPARENTE, OPALINO: le due superfici sono lucide.
Vetri ACIDATI: il lato principale del vetro è quello satinato.
mm 6÷7 - 10÷11

TRASPARENTE, OPALINO glass: both surfaces are polished.
ACIDATI glass: the main side of the glass is the etched one.
6÷7 - 10÷11 mm



VETRI COLORATI | COLOURED GLASS

BLUES

Vetro acidato satinato. Il lato principale è quello satinato. mm 6÷7 - 10÷11
Frosted glass. The main side of the glass is the etched one. 6÷7 - 10÷11 mm



SATINATI COPRENTI OPAQUE FROSTED GLASS

VELLUTO

Vetro coprente. Entrambe le superfici sono satinata,
colorazione interna. mm 6÷7 - 10÷11
Opaque glass. Both surfaces are etched,
inner coloring. 6÷7 - 10÷11 mm



SONG - RAL

Vetro coprente. Le due superfici sono lucide, colorazione interna. mm 6÷7 - 10÷11
Opaque glass. Both surfaces are polished, inner coloring. 6÷7 - 10÷11 mm



VETRI SEMI-RIFLETTENTI | SEMI-REFLECTIVE GLASS

SUPERSILVER TRASPARENTE

Il lato principale del vetro è quello semi-riflettente. mm 10÷11
The main side of the glass is the semi-reflective one. 10÷11 mm



SUPERSILVER SATINATO

Il lato principale del vetro è quello semi-riflettente. mm 10÷11
The main side of the glass is the semi-reflective one. The back side is etched. 10÷11 mm



SPECCHI | MIRRORS

SPECCHI BIFACCIALI

Specchio su entrambi i lati. mm 10÷11 - (CHIARO anche mm 6÷7)
Two-sided mirror. 10÷11 mm - (CHIARO: also 6÷7 mm)



SOFTMIRROR

Vetro coprente argentato satinato bifacciale. Le due superfici sono satinata. mm 10÷11
Opaque two-sided frosted silvered glass. Both surfaces are etched. 10÷11 mm



MIRRORSONG

Le due superfici sono lucide, una colorata ed una a specchio. Colorazione interna. mm 10÷11
Both surfaces are polished, one is colored and the other is mirrored. Inner coloring. 10÷11 mm

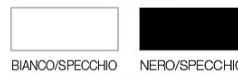

EXTRAMIRROR

Specchi bifacciali. Solo per decori acidati texture GALLES e MACRAMÉ. mm 10÷11
Two-sided mirrors. For GALLES and MACRAMÉ etched textures only. 10÷11 mm



VETRI TESSUTO | FABRIC GLASS

FLOU

Le due superfici sono lucide, tessuto all'interno. mm 6÷7 - 10÷11
Both surfaces are polished, with fabric between them. 6÷7 - 10÷11 mm



FOLK

Le due superfici sono lucide, tessuto all'interno. mm 6÷7 - 10÷11
Both surfaces are polished, with fabric between them. 6÷7 - 10÷11 mm



Finiture | Finishings

SERIE TOTAL | TOTAL SERIES

Finiture opache caratterizzate da una texture
goffrata che ne esalta il tatto e conferisce proprietà
antigraffio e antimpronta al legno.

Durable matte finishes characterized by a pleasant
texture to the touch, along with anti-scratch and
anti-fingerprint properties.



SERIE METALLIZZATI | METALLIZZATI SERIES

Finiture brillanti che richiamano il colore e
l'aspetto di metalli pregiati.

Bright finishes that mimic the color and
appearance of precious metals.

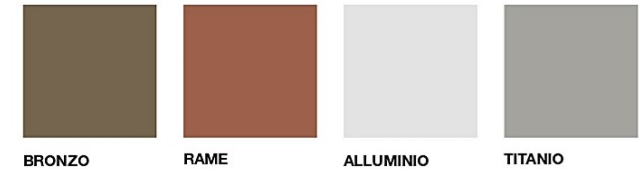

FINITURE SPECIALI | SPECIAL FINISHINGS

EFFETTO CORTEN | CORTEN EFFECT

Eseguito interamente a mano, rappresenta la massima
espressione dello stile industriale.

Executed entirely by hand, it represents the ultimate
expression of industrial style.



EFFETTO CORTEN
CORTEN EFFECT

RAL & NCS

Laccatura a scelta tra le migliaia di colori presenti
all'interno delle cartelle RAL e NCS.

Lacquer finish to be chosen from the thousands of
colors within the RAL and NCS palettes.

Maniglie | Handles

BATTENTE | SWING DOORS

PORTA CON
SERRATURA E MANIGLIA
DOOR WITH
KEYHOLE AND HANDLE

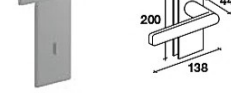

MP 2013 F

Maniglia

Handle

N B CRS
● ○ ●

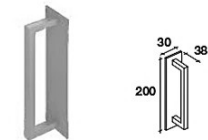

PORTA CON CHIUSURA
"EASY-LOCK"
DOOR WITH "EASY-LOCK"
SYSTEM

F 20

Maniglia fissa in metallo

Stessa finitura anta

Fixed metal handle

Same finish as the panel

SCORREVOLE - SCOMPARSA | POCKET-SLIDING DOORS

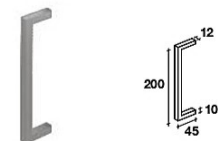

C/20

Maniglia stessa
finitura anta

Handle same
finish as the panel

PORTA A LIBRO | FOLDING DOORS

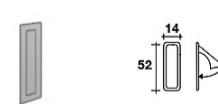

PDR

Pendolino entrambi i lati

Double-sided retractable knob

N B CRS
● ○ ●

Decor | Decorations

DECORI IN "VETRO LIQUIDO" TRASPARENTE E BLACK

Realizzabili sul lato principale di tutti i vetri. ESCLUSO VETRI TESSUTO. Anta larghezza max: 1200 mm

"VETRO LIQUIDO" TRANSPARENT AND BLACK DECORATIONS

To be implemented on the main side of all glass. EXCEPT FOR FABRIC GLASS. Max panel width: 1200 mm



T1

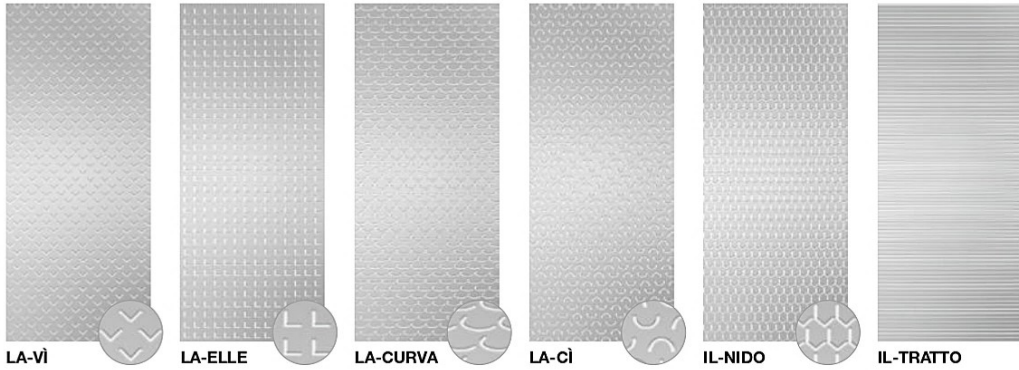

LA-VI

LA-ELLE

LA-CURVA

LA-CI

IL-NIDO

IL-TRATTO

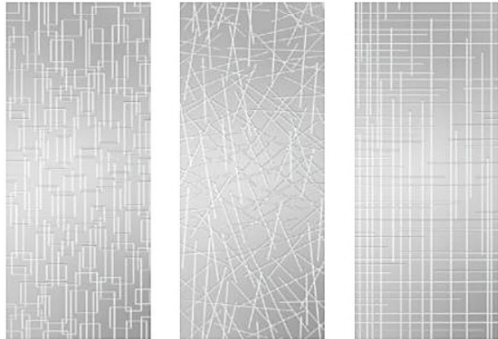

CADRE

SHANGHAI

GRAPHICS

POSIZIONI DEL DECORO | POSITIONS OF THE DECORATION

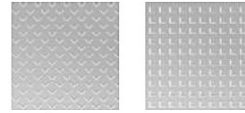

LA-VI

LA-ELLE

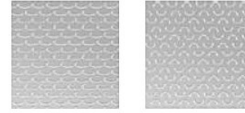

LA-CURVA

LA-CI

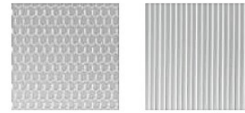

IL-NIDO

CANNETÉ

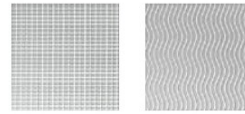

MILLIMETRATO

LE-ONDE

SCORREVOLE - SCOMPARSA - BATTENTE - BILICO SLIDING DOORS - POCKET DOORS - SWING DOORS - PIVOT DOORS

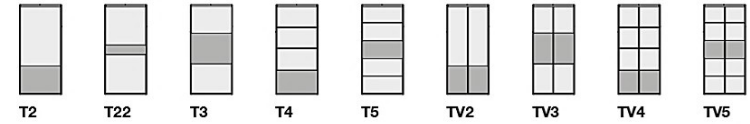

LIBRO FOLDING DOORS

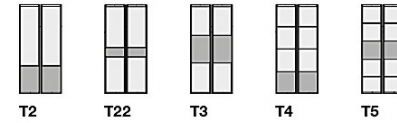

ANTA FISSA PER BILICO FIXED PANEL FOR PIVOT DOORS

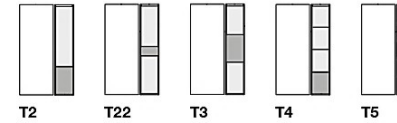

DECORO IN "VETRO LIQUIDO BLACK"

"VETRO LIQUIDO BLACK" DECORATION



LA-RETE

RIQUADRO VERNICIATO BIFACCIALE (STESSA FINITURA ANTA)

DOUBLE-SIDED PAINTED SQUARE (SAME FINISH AS THE PANEL)



SCORREVOLE - SCOMPARSA - BATTENTE - BILICO SLIDING DOORS - POCKET DOORS - SWING DOORS - PIVOT DOORS

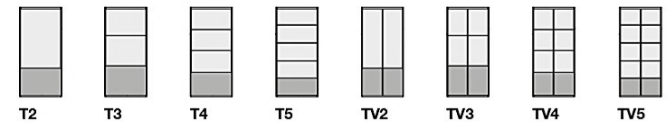

LIBRO FOLDING DOORS

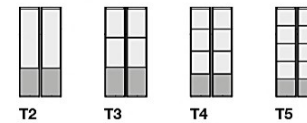

ANTA FISSA PER BILICO FIXED PANEL FOR PIVOT DOORS

